



MULTI-FREQUENCY FHRX-2 INSTRUCTION MANUAL

Thank you for purchasing the ATA FHRX-2 plug in two channel Receiver. Familiarise yourself with the following instructions prior to commencing set up. Store this information in a safe place for future reference. The FHRX-2 receiver has transistors on board which provide an open collector contact for controlling virtually any electronic garage door or gate.

BRAND OF TRANSMITTERS

The First memory location sets the type of transmitters which can be stored into the receivers memory. It either can be ATA TrioCode™ or B&D Tri-Tran™ transmitters. For example if first transmitter stored is TrioCode™ then rest of transmitters can only be the TrioCode™ type and mixing of TrioCode™ ,Tri-Tran™ is not possible. By deleting all stored transmitter codes from the receivers memory will allow you to choose either TrioCode™ or Tri-Tran™ transmitters again.

UNIVERSAL PROGRAMMER

An ATA Universal Programmer can be used to set timer (adjustable from 0.00 to 655.34 seconds), Edit, back up /restore transmitters.

STORING TRANSMITTER CODE

1. Press and hold SW1 (for channel 1) or SW2 (for channel 2) on the receiver board. The led D1 will start to flash
2. Press the transmitter button you would like to use to control the device for two seconds. The led will start to flash faster.
3. Release the transmitter button and pause for two seconds. Press the same button again for two seconds. The led will stays on for second and turns off.
4. Release SW button.
5. Press the transmitter button to test operation.

DELETING A SINGLE TRANSMITTER'S CODE

1. Press and hold SW1 (for channel 1) or SW2 (for channel 2) on the receiver board. The led will start to flash
2. Press the transmitter button you would like to remove from receivers memory for two seconds. The led will start to flash faster.
3. Release the transmitter button and pause for two seconds. Press the same button again for two seconds. The led will slowly flash two times
4. Release SW button.
5. Press the transmitter button to confirm that it has been removed.

DELETING ALL STORED TRANSMITTER CODES

1. Turn the power off to the receiver.
2. Press and hold SW1 button.
- 3 While holding SW1 turn power on again. After 15 seconds the Coding LED will illuminate to indicate that the receivers memory has been cleared.
4. Release SW1. All the stored codes should now be deleted. Confirm this by pressing the transmitters previously used to operate the device. There should be no response.

CO-AXIAL CONNECTION

An optional coaxial antenna is available for use with the receiver in difficult reception areas. The antenna has to be mounted as high as possible so that it is not obstructed, e.g. on top of a fence, or on a wall at the front of a garage, etc. Connect the core of coaxial lead to replace the existing antenna wire (outer screw socket). Connect shield to the spare (inner) screw socket.

HARNESS (OPTIONAL)

The harness to connect receiver to the opener can be bought from ATA (Order code #01905). User may have to cut and strip wires to connect to different openers. Cut and leave white wire if the second channel is not used.

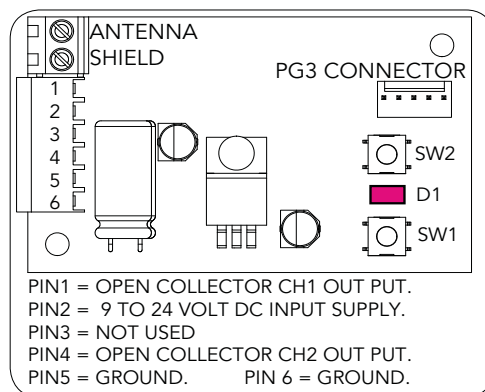

FHRX-2

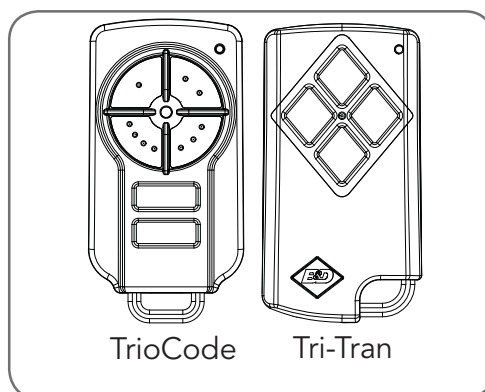

Transmitters

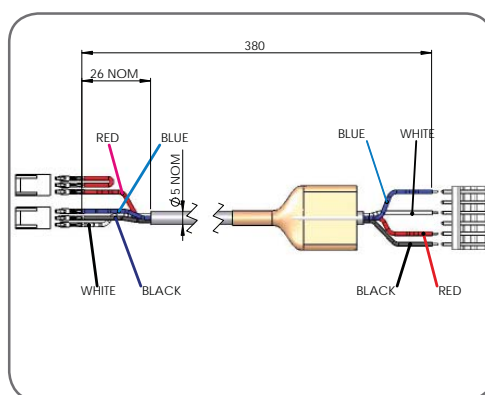

Harness to use with receiver



SPECIFICATIONS

Power Supply: 9 volts to 24 Volts DC ONLY

Frequency: Multi frequency

Memory Capacity: 250 Transmitters

Control Output 1 : Open collector output at pin one for channel one (40 dc volts 100ma max)

Control Output 2 : Open collector output at pin four for channel two (40 dc volts 100ma max)

HOW TO CONNECT RECEIVER WITH ATA HARNESS TO DOOR/GATE OPENERS:

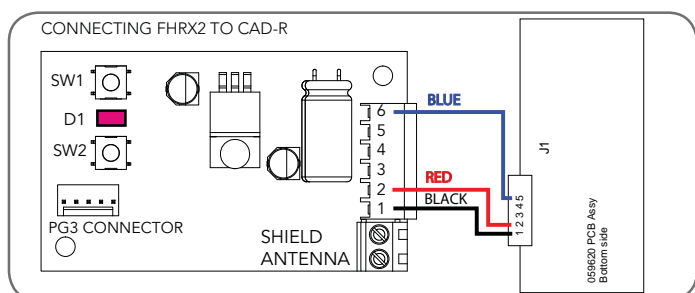
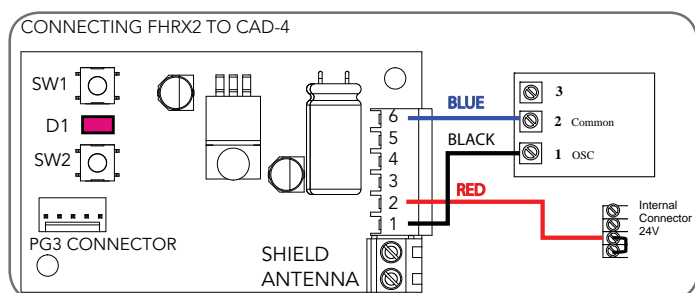
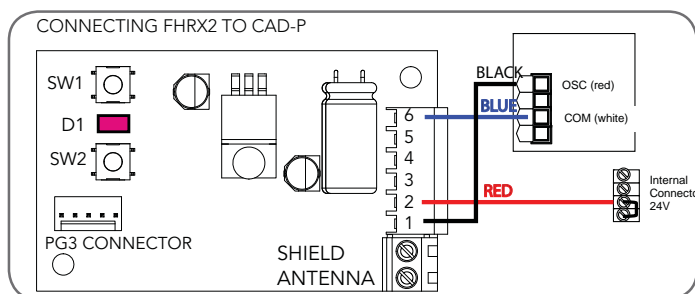
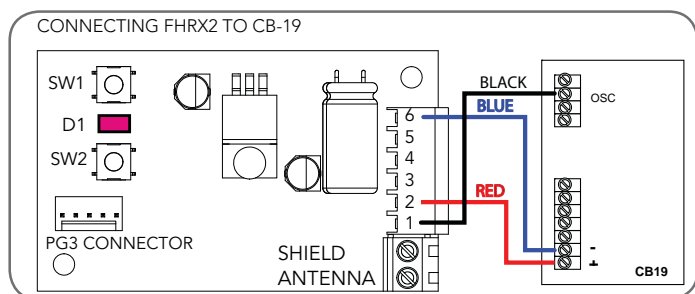
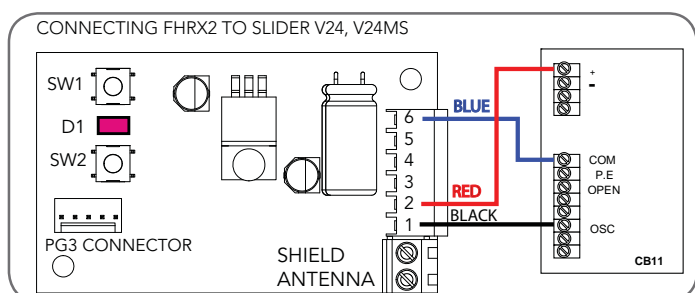
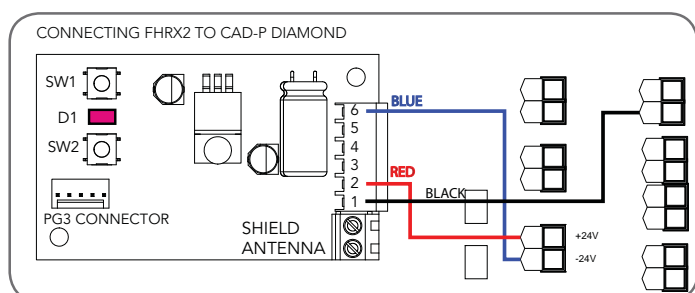
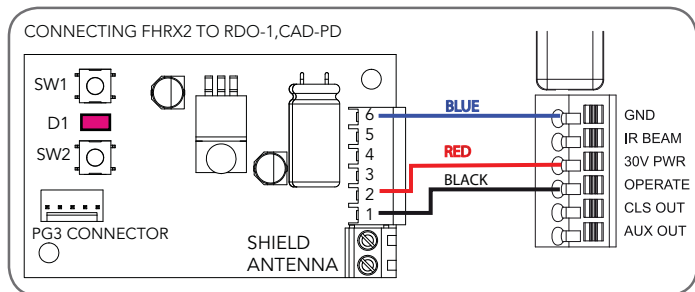
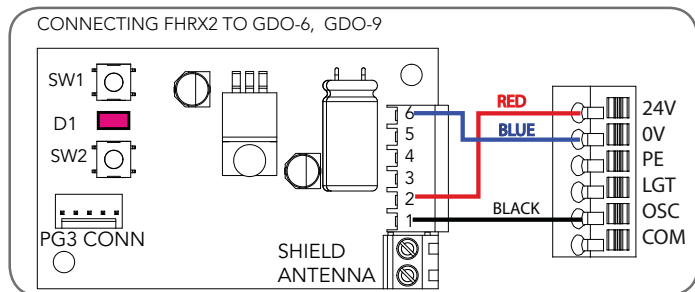

© May 2008 Automatic Technology (Australia) Pty Ltd. All rights reserved. TrioCode™ is trademark of Automatic Technology (Australia) Pty Ltd. No part of this document may be reproduced without prior permission. In an ongoing commitment to product quality we reserve the right to change specification without notice. E&OE.

automatic
TECHNOLOGY

smart | simple | secure

an alesco company

Automatic Technology (Australia) Pty Ltd

ABN 11 007 125 368

6-8 Fiveways Boulevard
Keysborough, Victoria, 3173, Australia

P 1300 133 944

+61 2 9722 5666 (International Enquiries Only)

E sales@ata-aust.com.au

www.ata-aust.com.au